

Name:			
Enrolment No:			
UNIVERSITY OF PETROLEUM AND ENERGY STUDIES End Semester Examination, May 2023			
Course:	Program Logic Controller & HMI	Semester:	VI
Program:	B. Tech (Mechatronics Engineering)	Time:	03 hrs.
Course Code:	ECEG 3055	Max. Marks:	100
Instructions: This question paper has three sections, Section A, Section B, and Section C.			
SECTION A (5Qx4M=20Marks)			
S. No.		Marks	CO
Q 1	Define onboard and inline I/O's, List out different onboard and inline I/O's.	4	CO1
Q 2	Explain why a stop button must be normally closed and a start button must be normally open.	4	CO2
Q 3	Describe the similarities and differences between PLC ladder logic and relay ladder logic.	4	CO3
Q 4	Summarize the tradeoffs between capacitive, inductive, and optical sensors.	4	CO3
Q 5	With technical details like data rate, frame format, and error handling method, explain the PROFIBUS communication protocol.	4	CO 1
SECTION B (4Qx10M= 40 Marks) (Answer any four questions)			
Q 6	In detail, describe the process of setting up analog inputs and outputs for all the configurations. OR Simplify the following boolean equation and implement it in ladder logic. $X = A + BA + B\bar{C} + \overline{D} + \bar{C}$	10	CO3
Q 7	In order to avoid high starting currents, three-phase asynchronous motors are firstly switched in a star connection and then, after a time delay, switched over into a delta connection. By activating the S1 pushbutton "Start", the star contactor K2 and the main contactor K1 are activated. The star contactor K2 is deactivated after a time delay of 5 s and simultaneously, the delta contactor K3 is activated. Now, the motor is running in nominal operation. By activating the S2 pushbutton "Stop" or the motor protection switch F2, the control is immediately set into the idle state. You have to note in the program preparation that the main contactor K1 may only be activated if contactor K2 has been activated. It must moreover be ensured that the star contactor K2 and the delta contactor K3 are never activated simultaneously. The respective switching states of the contactors are to be queried via S4 and S5. By means	10	CO4

	<p>of the message contacts S4 and S5, the control is transmitted to the current switching state.</p> <ol style="list-style-type: none"> 1. Determine the type of the signal encoders and receivers and prepare an assignment list. 2. Prepare a clamp connection plan. 3. Prepare the PLC program. 		
<p>Q 8</p>	<p>In a car parking station, a maximum of 100 cars can be parked. Two photoelectric sensors are placed in the station Entry and OUT gate to sense the entering and leaving cars. Based on the number of cars parked in station three different color lamps got switched ON.</p> <ol style="list-style-type: none"> 1. When no car is in the parking station Green Lamp is switched ON 2. If the no. of cars from 1 to 99 Yellow Lamp is switched ON 3. If no. of cars in the station is equal to 100 Red Lamp is switched ON 	<p>10</p>	<p>CO 4</p>
<p>Q 9</p>	<p>Design a PLC ladder diagram and hardware configuration for the DC motor control using the PWM method. With a potentiometer vary the duty cycle and accordingly, the speed of the motor should change. As shown below figure, use an appropriate relay to match the current rating.</p> 	<p>10</p>	<p>CO 4</p>
<p>SECTION-C (2Qx20M=40 Marks)</p>			

<p>Q 10</p>	<p>Design a hydraulic circuit and write a ladder program to implement the bending device for sheet metal parts to be performed on a workpiece. The sequence of motion of cylinders is:</p> <ol style="list-style-type: none"> Cylinder 1 clamp the workpiece Cylinder 2 performs bending operation on a workpiece Cylinder 2 return backs Cylinder 3 performs bending operation on a workpiece Cylinder 3 return backs Cylinder 1 unclamps the workpiece. <p>(Consider the appropriate directional control valve and the default position is the home position)</p>  <p style="text-align: center;">Example of application: "Bending aluminum into hooks"</p>	<p>20</p>	<p>CO5</p>
<p>Q 11</p>	<p>The selective band switch is switched on using the S1 pushbutton "Start" and switched off using the S2 pushbutton "Stop". On a conveyor band, the selective band switch is supplied with long and short workpieces in an arbitrary order. After switch on of the system, the selective band switch is to drive into position "A". If a long piece runs through the scanning device, all 3 light barriers will be covered for a short period of time and the selective band switch remains in position "A". If a short piece runs through the scanning device, the light barriers are activated individually. The switch moves in position "B". The position "B" must be maintained for a period of 5 s. After expiry of the time or if a long work piece is fed in, the selective band switch is to return into position "A" again. Pump 1: 3 kW. Optionally, the cylinder switches S3 and S4 can be used for monitoring the selective band switch position.</p> <ol style="list-style-type: none"> Determine the type of the signal encoders and receivers and prepare a variable declaration table. Prepare a clamp connection plan. Prepare the PLC ladder program. 	<p>20</p>	<p>CO5</p>

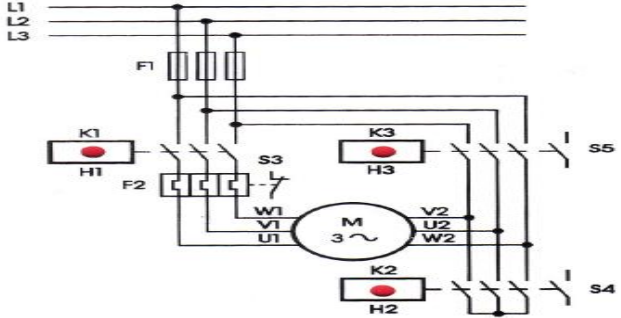
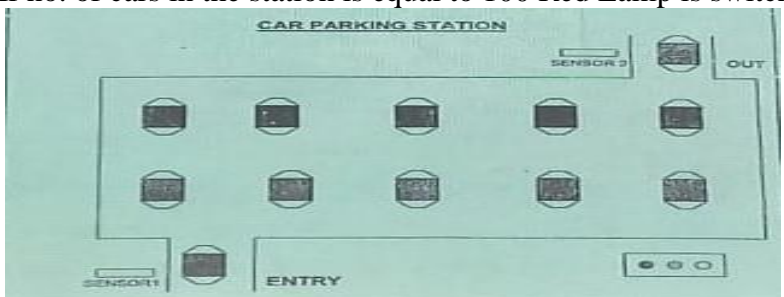
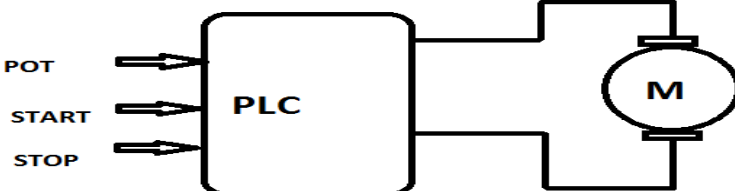
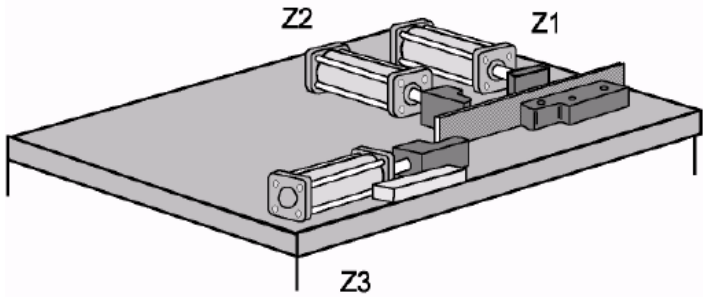
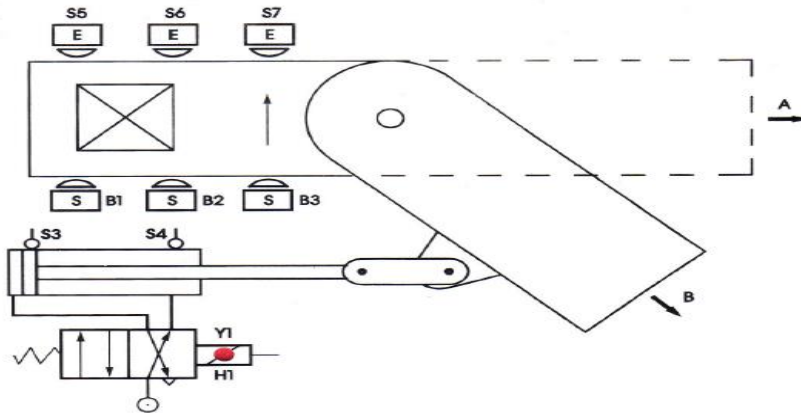

OR

For the stepper motor, consider minimum step angle is 1° and the pulse train to run the motor is generated by the PLC.

- a) How many pulses are required to rotate the motor through 10 complete revolutions?
- b) If it is desired to rotate the motor at a speed of 25 rev/min, what pulse rate must be generated by the robot controller?

Write a ladder logic program to rotate the stepper motor 10 times clockwise and 10 times in a counterclockwise direction.

